

**BIO-INFORMATICS**  
**IRONCLAD -**  
**AN INNOVATIVE**  
**APPROACH TO STOP**  
**FLIGHT HIJACKING**

[www.technicalpapers.co.nr](http://www.technicalpapers.co.nr)

## **ABSTRACT:**

In the era of modern technology and high-end violence the fear of survival is always there when we are in air amusing the plane. In this paper we have given an inneuendo in stopping hijacking in the most effective way. This method involves implementation of Embedded system and biomedical Instrumentation.

IRONCLAD means an unassailable method or a flawless device. This is a new method using the Functional System of the body. This will certainly put a Full stop to the things that threatens everyone, if it is implemented correctly. The IRONCLAD deals with the detection and prevention of hijacking automatically by combining the features of embedded and biomedical instrumentation for sensing the parameters.

Embedded system is used because any additions or an alteration in the system does not involve the change of hardware that could be done just by changing the coding written in the IC. This reduces hardware cost, development time and space. These chips are built into a non-computing device, which gives intelligence to the system. Biomedical instrumentation provides necessary equipments for sensing the required parameters from the body. The camera gives the control to the system and for alerting the pilot.

## **INTRODUCTION:**

The most intimidating part in this is the fear of hijackers seizing control of the plane. Even in the developed nations with the most sophisticated techniques couldn't stop these death including methods. IRONCLAD means an unassailable method or a flawless device. We have devised a new method using the functional system of the body. This will certainly put a full stop to the things that threatens everyone, if it is implemented correctly.

The IRONCLAD deals with the detection and prevention of hijacking automatically by combining the features of embedded and biomedical instrumentation for sensing the parameters. Embedded system is used because any additions or an alteration in the system does not involve the change of hardware that could be done just by changing the coding written in the IC. This reduces hardware cost, development time and space. These chips are built into a non-computing device, which gives intelligence to the system. Biomedical instrumentation provides necessary equipments for sensing the required parameters from the body. The camera gives the control to the system and for alerting the pilot.

Two types of sensors, heart beat and temperature sensors are used in here. These sensors are placed in all the passenger's seats. The heartbeat and temperature of the human body are measured and are constantly checked. There is always a quantum jump in the heartbeat count and the temperature of the human body in times of tension. So incase of any hijack, the human body will experience the same, which is detected by the sensors and suitable preventive measures are taken automatically.

## **PRINCIPLE:**

Whenever the brain senses any peril of any sort there is always certain reaction taking place in our body. this functional change of the body is used to detect the danger inside an aeroplane.the heartbeat and body temperature of a normal person rises abruptly

during this situation; this variation in the body is detected for each and every passenger inside the cabin of the aeroplane. The detecting sensors are placed in the seats of all the passengers inside the aeroplane. The temperature is detected by using temperature sensor and heartbeat by an infrared transmitter and receiver arrangement with a pulse generator. The values sensed from the sensors are added and the mean value is founded. When there is a quantum change in the heartbeat count and body temperature the mean value exceeds a normal value. Then the microcontroller gives the control to each station and activates the camera inside the flight. The situations are monitored manually and the controls are given to the flight accordingly. The controller used for this purpose is programmable interface controller (PIC) which has many features inbuilt in it, that satisfies the requirements needed here.

#### **NEED FOR IRONCLAD:**

In this modern and technocratic world the threats for hijacking is augmented successively. The attack on the WTC is the best example to show the increased threats and the devastating result. The aero plane is mainly focused for the abductions and threats since the passengers are mostly important people and locating of a particular person is not that difficult. Once the plane is in the air we lose our controls over it, this enables the hijackers to use the situation. So a sophisticated system with at most secrecy should be employed to avoid these miss happenings. The method we suggested would provide a required solution.

#### **COPING WITH THE PRESENT:**

The IRONCLAD is easy to install in any prevailing planes provided they need the security to the passengers. The system consists of the sensors, cameras, microcontroller and an interfacing device. The sensors are embedded to the seats of the passengers and have contacts with the microcontroller. The cameras are situated in various places in the plane cabin. As the system is totally embedded the installation is easier and simple. The system is enabled once the plane starts and works till the destination is arrived.

### **ANALYSIS AND WORKING:**

#### **SENSING AND REPORTING:**

The heartbeat sensors and the temperature sensors placed in the seats constantly give the signals to the microcontroller. The changes in the heartbeat count and the body temperature are reported then and there to the microcontroller.

#### **MICROCONTROLLER TASKING:**

The sensed values from the various sensors are handled individually and the mean for the heartbeat and the body temperature are found separately the mean values are compared constantly with the normal mean store previously in the microcontroller. Only when there is a change in the mean value by larger difference, an alert signal is sent to the earth station with the plane details and the cameras in the plane are activated simultaneously. Here the precision plays an important role. There may be sudden change in heart beat count or the body temperature of one or two passengers inside the plane. But this will don't do any major change in the mean value there by avoiding the unwanted alert signal produced.

#### **MANUAL MONITORING:**

Once there is an alert signal is given by the microcontroller, the cameras are activated and are viewed in the earth station. When the situation seen by the cameras doesn't show any disruptions a low level alert signal is given to plot since the hijackers may be hiding. If the situation is worse, a gas is released in the cabins. The gas as a nature of making the human being unconscious when inhaled. If there is no attention via the cameras, and the pilot or the earth station, the gas is released automatically after a minute.

### CONTROLLED SITUATION:

The camera used here enables the monitoring earth station to show the actual position in the plane. An emerging crew may be altered to get ready to be effective once the plane lands. The gas used should be mild and also should fulfill the requirement. Nitrous oxide or attar may be used here. Nitrous oxide is one of the best toxicant used for medical purpose. An output from the controller can be set to enable the autopilot if we suppose there may be a problem with the pilot.

### DESIGNING AND IMPLEMENTATION

#### FLIGHT CONTROL

##### 3.1BLOCK DIAGRAM

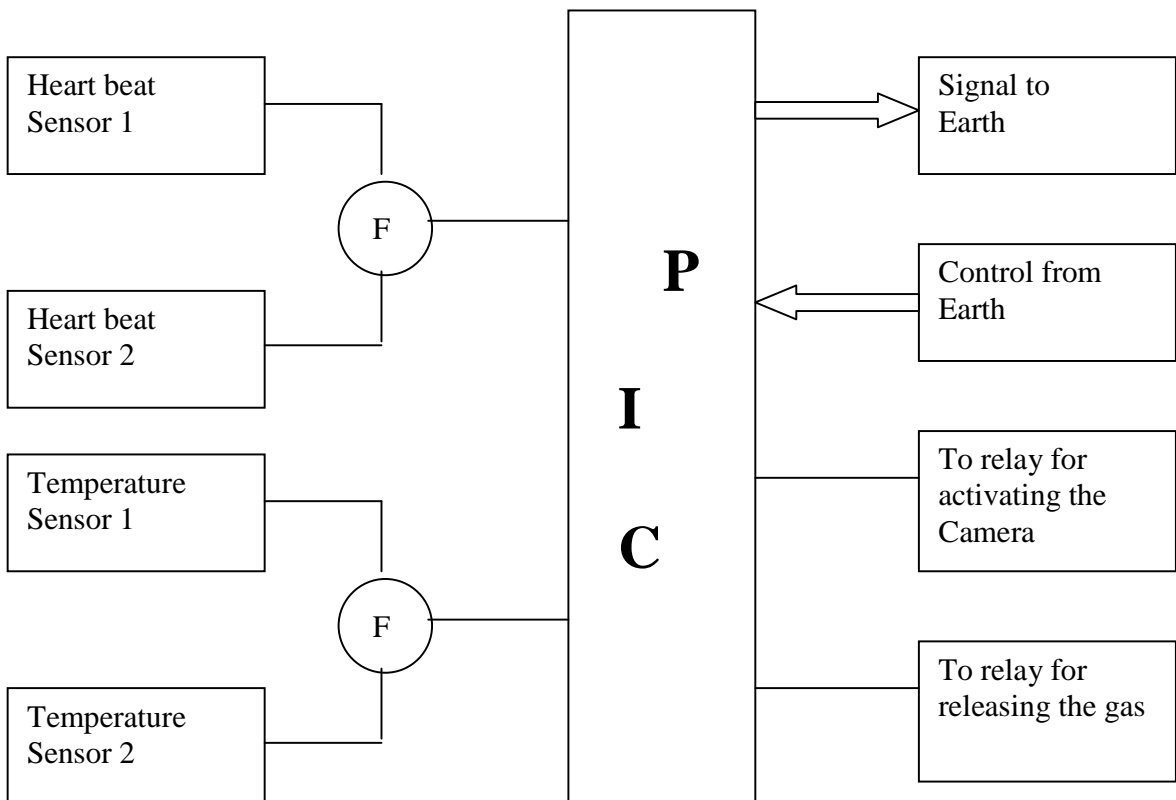

### 3.1 BLOCK DIAGRAM

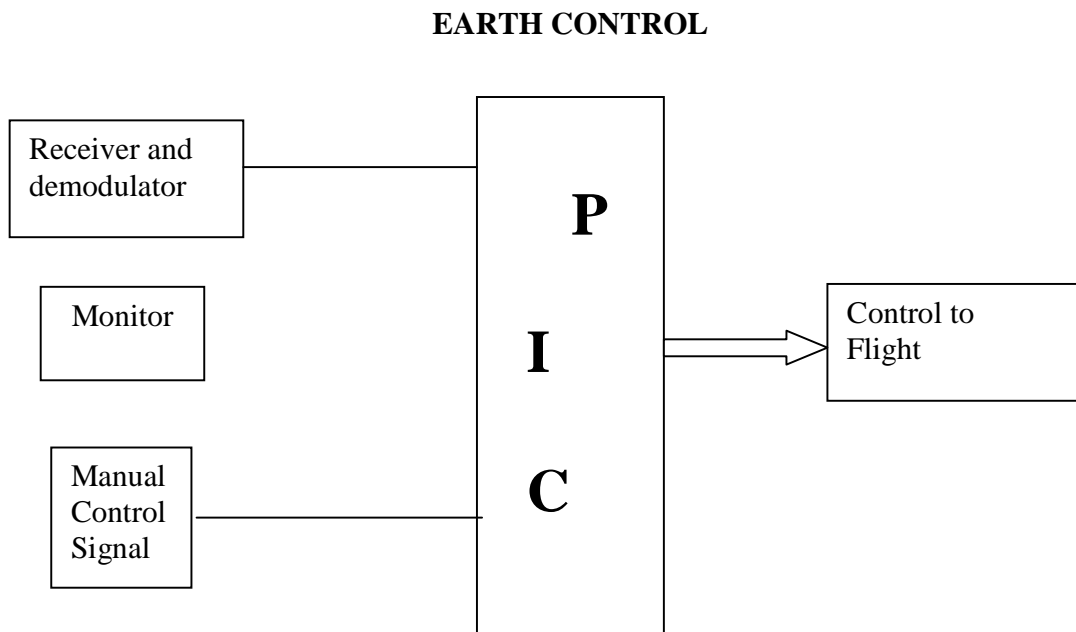

### 3.1 EMBEDDED DESIGN:

A system designed to perform a specific function that combines the feature and feature and functionalities. An Embedded system includes the microprocessors and micro controllers. Some of its advantages include.

- Faster execution speed.
- Higher reliability since less number of components.
- Reduced failure ratio.

### 3.2 APPLICATION:

The important feature required for this application is the detection of the condition of hijack and its protection. This could be done using the available hardware but it involves complex circuitry and would definitely increase cost and frame time. Also any further change in the system may require change of whole of the hardware and hence the whole system. Also time consumed in this should be considered. These factors can be completely eliminated in embedded system.

#### **4. HEART BEAT SENSOR:**

The conversions of the heart sounds into electrical signals can be done by a variety of transducers viz., condenser microphone, moving coil microphone, piezoelectric crystal, carbon microphone, etc. there are two, main categories of microphone used in phonocardiography.

1. Air coupled microphone.
2. Contact microphone.

In air-coupled microphone, the movement of chest is transferred (via) an air cushion and presents low mechanical impedance to the chest. But in contact microphone, it is directly coupled to chest wall and presents a higher impedance, high sensitivity, and receiver arrangement with a pulse generator we can sense heartbeat, which converts each heartbeat into corresponding electrical pulse. This arrangement will suit for implementation in here. The normal heartbeat of the person is at the rate of 72-75 beats per minute. This pulse differs from person to person and only an indicator of resting pulse rate is employed here.

The “normal” pulse rate for men is 72-bpm and for women it is 80 bpm. The pulse may be measured at the wrist, neck, temple plates, and groin, behind the knees or on the top of the foot. In these areas the artery passes close to the skin. In here the heartbeat is measured at the tip of the finger, preferably thumb finger. The heart beat sensor consists of an IR transmitter and a receiver. The transmitted IR radiation senses the blood flow. Blood is pumped for each heart beat pulses. Hence for each heart beat the transmitted IR radiation is interrupted by the flow of blood, which acts as resistance. The receiver senses this difference and an equivalent voltage is produced. Corresponding to the voltage pulses are generated by the pulse generator. These pulses are given as an input to the controller and from there the values are processed.



## **5. TEMPERATURE SENSOR (LM 335):**

The LM 335 series are precision easily calibrated integrated circuit temperature sensors operating as a two terminal sensor. The LM 335 has a breakdown voltage directly proportional to absolute temperature at  $10\text{mv}/^\circ\text{K}$ . With less than  $1\text{W}$  dynamic impedance the device operates over a current range of  $400\mu\text{A}$  to  $5\text{mA}$  with virtually no change in the performance.

Unlike the other sensor the LM 335 has a linear output. The applications for LM 335 include almost any type of temperature sensing over a  $-40^\circ\text{C}$  to  $+100^\circ\text{C}$  temperature ranges. The low impedance and the linear output make interfacing to read out or control circuitry especially easy.

### **FEAUTURES:**

- Directly calibrated in Kelvin.
- $1^\circ\text{C}$  initial accuracy is available.
- Operates from  $400$  to  $5\text{mA}$
- Easily calibrated.
- Wide operating temperature range.

### **PIC CONTROLLER:**

PIC controller is one of the versatile device by which the interfacing and working is easier. As the name implies the programmable interface controller is exclusively designed for peripheral interfacing.

### **FACTS ABOUT PIC:**

- ❖ It has a 16 bit flash memory.
- ❖ It is 1-lakh times erasable and writable.
- ❖ Code protection is available.
- ❖ Data retention is about 75 years.

## **6. PROBABLE PROBLEMS:**

There are some problems, which may arise when the hijack system control system is used. The problems and their solutions are discussed below:

### **PROBLEM 1:**

If there is a case where the hijacker wears safety masks and may resist the gas.

### **SOLUTION:**

An alternate way of making unconscious maybe chosen like lowering the oxygen level inside the cabin. This will make every person inside the cabin fall sleep.

### **PROBLEM 2:**

The hijacker may take control over the pilot and thereby the plane.

### **SOLUTION:**

By switching on the "AUTO PILOT" mode the plane can control itself. By looking at the camera an apt solution can be brought at that instant.

### **PROBLEM 3:**

The passengers may attain the abnormal condition in many situations like:

1. Any one of the passengers may be severely ill so that others may fear about those persons.
2. The plane may be about to crash due to any failures and there may be a condition for emergency landing and immediate evacuation from the plane. In such situation ii the patients were unconscious then it will lead to disaster.

**SOLUTION:**

Once there is an emergency situation, an indicator in the cockpit will glow indication the situation only if the indicator is left unattended the gas will be released. This gives the pilot ensure the safety of the passenger's inside.

**7. FUTURE APPLICATIONS:**

- ✓ This can used all security systems like banks, buses, cars, and houses. In these applications public police or detective agencies control the controls.
- ✓ This same idea can be used in — patient monitoring systems for emergency situations to give the doctor an indication in hospitals.
- ✓ The biomedical application can be further developed with wireless technology to monitor the status of a person while on the move.

**8. CONCLUSION:**

Even in the slightest possibility we should not allow mankind to face danger. This is impossible but the effort should not be ceased in any way. Every person should come whole heartedly to ensure security to the civilians against the most vicious persons present. This is one of the ideas, which provides security in an AEROPLANE against hijackers. This method may have flaws and hard less as it's in the preliminary stages, when it comes to real time problem will be overcome and it can be implemented successfully.

Reference:

[www.technicalpapers.co.nr](http://www.technicalpapers.co.nr)